

Magnet wire termination

The tough, high temperature insulation on magnet wire used by electrical motor and transformer manufacturers creates problems in splicing and terminating. The durability of magnet wire insulation has made dip-soldering or brazing extremely difficult without stripping the insulation.

Another splicing and terminating challenge involves the use of aluminium for magnet applications. A manufacturer connecting aluminium magnet wire to copper is faced with the problem of the different coefficients of thermal expansion of the two metals, galvanic corrosion, cold flow and the rapid formation of oxide film on the wire surface.

In the conventional methods, different techniques are used to remove the insulating varnish:

- scratching
- brushing
- burning-off
- dissolving

These methods are all costly and time consuming, and they generally lead to a risk of damage to the conductors and to a risk of injury of the operator. Health and environmental considerations can also be an issue.

The solution from Thomas & Betts: Dragon Tooth®, the insulation piercing connector

Thomas & Betts offer a solution for a highly reliable connection method for magnet wire, which eliminates welding, no longer requires removal of insulation and which can be installed in seconds. No special operator skills are needed.

The connector and matching tooling do the entire job. To meet the essential requirements of magnet wire connections, Thomas & Betts offer the insulation piercing Dragon Tooth® compression connector.

Dragon Tooth® magnet wire Connectors penetrate the insulation and oxide layers to make electrical contact on magnet wiring, eliminating the need for stripping, brazing, welding or other methods of joining magnet wire.

The result is a gas-tight, permanent connection with an exceptionally low contact resistance, capable of maintaining contact integrity throughout the life of the connection.



Scratching



Brushing



Burning-off

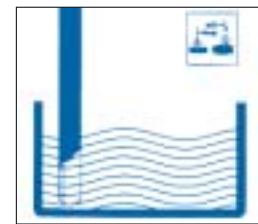

Dissolving

Dragon Tooth® connectors transform the perpendicular compression force, which would normally contribute to conductor creep, into distributive forces that effectively resist cold flow.

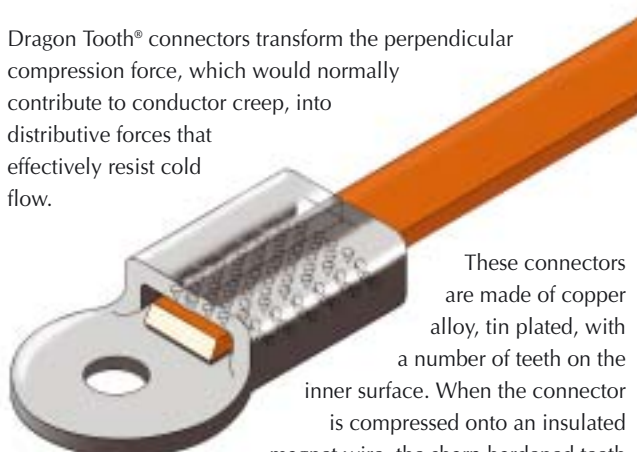

These connectors are made of copper alloy, tin plated, with a number of teeth on the inner surface. When the connector is compressed onto an insulated magnet wire, the sharp hardened teeth penetrate the insulation and the oxide and bite into the conductor. An electrically sound, low-resistance connection is established as a result of the combination of high pressures at the tip and edges of the teeth and the sliding action between the teeth and the conductor

Dragon Tooth®

Insulation piercing connectors

Dragon Tooth®: main features & typical applications

Thomas & Betts Dragon Tooth® connectors and installing tools are designed to splice, tap and terminate copper magnet wire from 32 AWG to 460,000 CMA (0,03 to 230 mm²) and aluminium magnet wire from 20 AWG to 460,000 CMA (0,5 to 230 mm²) in motor and transformer applications.

- Can be installed in seconds
- Requires minimal training for installation.
- Made of copper alloy, tin plated, with a number of teeth on the inner surface
- Splices and taps have an open side permitting easy access to wire and makes internal coil tapping possible (mid-span tapping and splicing)
- For aluminium to copper, aluminium to aluminium, or copper to copper magnet wire connections
- Ring terminals with bolt holes to accommodate M3 through M12 studs
- Male and female 6.35 mm x 0.8 mm disconnects
- Splices and fork terminals accommodate wire sizes 24 AWG (0.21 mm²) to 12 AWG (3.3 mm²) in a variety of combinations, including combining magnet wire with stripped wire lead. For solid or stranded wire 20 AWG (0.52 mm²) to 4/0 AWG (107.2 mm²)
- Larger connectors accommodate circular mil range from 50,000 to 460,000 CMA (25 to 230 mm²)
- Transition washers with teeth to penetrate aluminium and copper oxides, enabling copper to aluminium connections to be made in a bolted joint without the use of inhibiting compounds

Transition washers also accommodate the difference in thermal expansion between copper and aluminium, and enhance the efficiency of bolted grounding connections

- Connector and matching tooling do the entire job

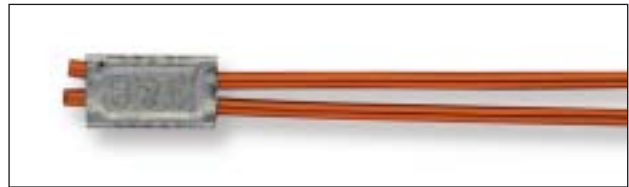

Splice



Parallel Splice



Tap

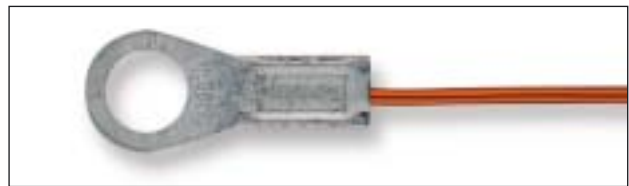

Termination

How to Select a Connector

1. Define the cross-section of the conductors (see formula on next page) and in the Ordering Information tables, refer to either Round Wire column, or Rectangular column, depending on the type you are using, and check any limitations, (such as max. wire i.e. width/height). If there are limitations, you may have to make a selection from next larger size.
2. Refer to table on page 340 for lead wire to magnet wire applications, to table on page 341 for magnet wire to magnet wire applications for the series 22L00X and 22000X.
3. Once the connector is defined, the appropriate tool and die for the application can be selected in the selection chart on pages 358 and 359.

Formula for calculating circular mil area (CMA)

For square or rectangular wire: CMA = Thickness (inch) x Width (inch) x 1.273E6
 = Thickness (mm) x Width (mm) x 1.973E3

For round wire: CMA = (Diameter (inch))² x 1E6
 = (Diameter (mm))² x 1.55E3

See table below for values

Unit conversion table: AWG round wire size to diameter and cross-section

WIRE SIZE AWG	NOMINAL DIAMETER [inch]	NOMINAL DIAMETER [mm]	CROSS- SECTION [mm ²]	CMA CIRCULAR MILS [cmil]
4/0	0.4600	11.684	107.219	211600
3/0	0.4096	10.404	85.011	167800
2/0	0.3648	8.547	67.432	133100
1/0	0.3249	8.252	53.488	105600
1	0.2893	7.348	42.409	83690
2	0.2576	6.543	33.624	66360
3	0.2294	5.827	26.655	52620
4	0.2043	5.189	21.149	41740
5	0.1819	4.620	16.766	33090
6	0.1620	4.115	13.289	26240
7	0.1443	3.665	10.551	20820
8	0.1285	3.264	8.387	16510
9	0.1144	2.906	6.632	13090
10	0.1019	2.588	5.262	10380
11	0.0907	2.304	4.168	8230
12	0.0808	2.052	3.308	6530
13	0.0720	1.829	2.627	5180
14	0.0641	1.628	2.082	4110

WIRE SIZE AWG	NOMINAL DIAMETER [inch]	NOMINAL DIAMETER [mm]	CROSS- SECTION [mm ²]	CMA CIRCULAR MILS [cmil]
15	0.0571	1.450	1.652	3260
16	0.0508	1.290	1.308	2580
17	0.0453	1.151	1.040	2050
18	0.0403	1.024	0.823	1620
19	0.0359	0.912	0.653	1290
20	0.0320	0.813	0.519	1020
21	0.0285	0.724	0.412	812
22	0.0253	0.643	0.324	640
23	0.0226	0.574	0.259	511
24	0.0201	0.511	0.205	404
25	0.0179	0.455	0.162	320
26	0.0159	0.404	0.128	253
27	0.0142	0.316	0.104	202
28	0.0126	0.320	0.080	159
29	0.0113	0.287	0.065	128
30	0.0100	0.254	0.051	100
31	0.0089	0.226	0.040	79
32	0.0080	0.203	0.032	64

Note: 1 kcmil = 1000 cmil

Unit conversion table: American bolt sizes

US BOLT SIZE	MIN. HOLE DIAMETER [mm]	MIN. HOLE DIAMETER [inch]	MATCHING BOLT IN METRIC SIZE
2	2.337	0.092	M2
4	2.946	0.116	M2.5
6	3.632	0.143	M3
8	4.292	0.169	M4
10	4.978	0.196	M6
1/4	6.655	0.262	M8
5/16	8.204	0.323	M6
3/8	9.855	0.388	M8
7/16	11.506	0.453	M8
1/2	13.106	0.516	M12
5/8	16.510	0.650	M14
3/4	19.685	0.775	M18

Dragon Tooth®

Splices

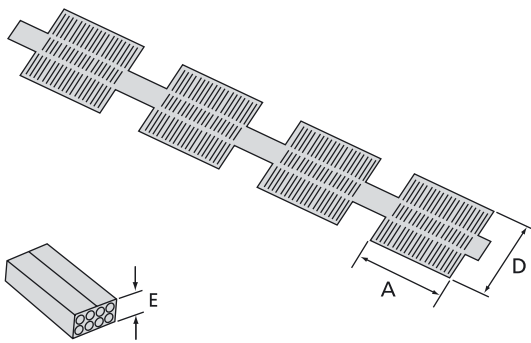

Approvals



E9809

Ordering Information

PRODUCT REF.	DIMENSIONS			COMBINED WIRE SIZE	ROUND	RECTANGULAR WIRE RANGE		TOOLING
	A	D	E*		WIRE RANGE	WIRE THICKNESS	WIRE WIDTH	
	[mm]	[mm]	[mm]	[mm ²]	MIN - MAX	MIN - MAX	MIN - MAX	
220004	4.7	2.8	0.8	0.23 - 0.87	0.20 - 1.00**	-	-	13676A
220001	8.7	4.4	2.4	0.64 - 3.30	0.40 - 1.45**	0.60 - 1.00	0.60 - 2.30	13678
220006	11.9	6.4	2.4	1.30 - 6.24	1.30 - 2.05	1.30 - 2.05	1.30 - 4.10	13696
220002-TB	8.7	6.4	2.4	1.00 - 3.30	0.50 - 1.40**	0.50 - 1.00	0.50 - 2.30	13679

* Reference dimension (crimped height): see installing die illustration for gauging

** Not recommended for aluminium magnet wire finer than 0.4 mm²

See pages 354 to 359 for tooling specifications

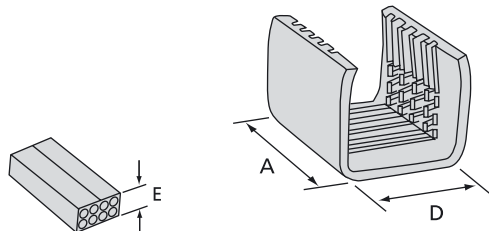

Approvals



E9809

Ordering Information

PRODUCT REF.	DIMENSIONS			COMBINED WIRE SIZE	ROUND	RECTANGULAR WIRE RANGE		TOOLING	
	A	D	E*		WIRE RANGE	WIRE THICKNESS	WIRE WIDTH	HAND TOOL	POWER TOOL***
	[mm]	[mm]	[mm]	[mm ²]	MIN - MAX	MIN - MAX	MIN - MAX		
22L004	3.8	2.8	1.3	0.23 - 0.87	0.20 - 1.00**	-	-	ERG1804	
22L001	8.1	4.1	2.5	0.20 - 2.10	0.50 - 1.45**	0.50 - 1.25	0.50 - 2.50	ERG1801	11903A
22L002	8.1	6.4	2.5	1.00 - 3.30	0.50 - 1.40**	0.50 - 1.25	0.50 - 2.80	ERG1802	11904A
22L006	11.5	6.4	3.3	1.30 - 6.24	1.30 - 2.05	1.30 - 1.50	1.30 - 4.10	ERG1806	13500
22L008	17.8	12.7	3.8	6.50 - 15.50	1.00 - 1.30	1.00 - 1.60	1.60 - 9.53	-	13100A, 13400
22L009	17.8	14	5.6	18.30 - 43.60	1.30 - 2.58	2.00 - 4.60	2.00 - 9.50	-	TBM15i

* Reference dimension (crimped height): see installing die illustration for gauging

** Not recommended for aluminium magnet wire finer than 0.4 mm²

*** Use selection chart to determine appropriate die set (pages 358 and 359)

See pages 354 to 359 for tooling specifications

Dragon Tooth®

Splice selection guide

For lead wire to magnet wire applications

For 22L00X and 22000X series terminals



MAGNET WIRE SIZE	LEAD WIRE SIZE					
	3.3 [mm ²]	2 [mm ²]	1.5 [mm ²]	1 [mm ²]	0.5 [mm ²]	0.3 – 0.2 [mm ²]
2 – 1.5 mm ²	220006 22L006	220006 22L006	220006 22L006	–	–	–
1.3 mm ²	220006 22L006	220002 22L002	220002 22L002	22L001	22L001	–
1.0 mm ²	22L006	22L002	22L001 22L001	220001 22L001	220001	–
0.8 – 0.3 mm ²	22L002	220002 22L002	220001 22L001 220002 22L002	220001 22L001	220001 22L001	–
0.2 mm ²	22L002	220002 22L002	220001 22L001 220002 22L002	220001 22L001 22L004	220001 22L001 220004 22L004	220004 22L004
0.12 mm ²	–	–	22L001	22L001 22L004	22L001 220004 22L004	220004 22L004
0.08 mm ²	Not recommended for aluminium Magnet Wire finer than 0.5 mm ²		–	22L004	220004 22L004	220004
0.05 mm ²	–	–	–	220004 22L004	220004 22L004	220004 22L004
0.03 mm ²	–	–	–	22L004	22L004	22L004

Dragon Tooth®

Splice selection guide

For magnet wire to magnet wire applications

For 22L00X and 22000X series terminals

MAGNET WIRE SIZE	WIRES PER CONNECTION												
	2	3	4	5	6	7	8	10	12	14	16	20	24
16 mm ²	22L009		22L009H										
5 mm ²					22L009				22L009H				
3.3 mm ²							22L009				22L00H		
2 mm ²	220006	220006		22L008				22L009					
	22L00	22L006											
1.5 mm ²	22L002	220006											
	220009	22L006											
	22L009												
1.3 mm ²	22L002	220006	220009			22L008			22L009		22L009H	22L009H	
	220006	22L006	22L006										
	22L006												
1.0 mm ²	22L001	22L002											
	22L002												
0.8 mm ²	22L001	22L002	22L002				22L008						
	22L002												
0.6 mm ²	22L001	22L002	22L002	22L002									
	22L002												
0.5 mm ²	22L001	22L001	22L002	22L002	22L002								
	22L002	22L002											
0.4 - 0.3 mm ²	22L001	22L001	22L001										
0.25 mm ²	22L001	22L001	22L001	22L001									
0.2 mm ²	22L004	22L001	22L001	22L001	22L001								
	22L001												
0.12 mm ²	22L004	22L004											
0.08 mm ²	22L004	22L004	22L004										
0.05 mm ²	22L004	22L004	22L004	22L004									
0.03 mm ²	22L004	22L004	22L004	22L004	22L004								

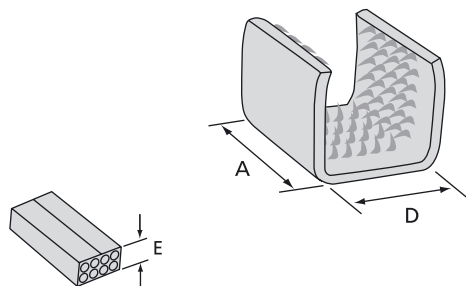

Approvals



E9809

Ordering Information

PRODUCT REF.	DIMENSIONS			COMBINED WIRE SIZE	ROUND	RECTANGULAR WIRE RANGE		TOOLING
	A	D	E*		WIRE RANGE	WIRE THICKNESS	WIRE WIDTH	
	[mm]	[mm]	[mm]		MIN - MAX	MIN - MAX	MIN - MAX	
210214S	15.9	9.5	4.3	2.00 - 10.52	1.63 (a) - 2.58	2.00 - 2.30	2.00 - 4.57	13100A, 13400
204210S	17.5	13.5	6.3	5.20 - 26.60	2.05 (b) - 6.54 (c)	2.50 - 4.10	2.50 - 6.35	TBM15i

* Reference dimension (crimped height): see installing die illustration for gauging
 Use selection chart to determine appropriate die set (see pages 358 and 359)
 See pages 354 to 359 for tooling specifications

(a) Four wires max
 (b) Six wires max
 (c) Crimping dies may not bottom

Connector height will depend on number and sizes of wires in barrel
 Pump must deliver 9800 PSI minimum

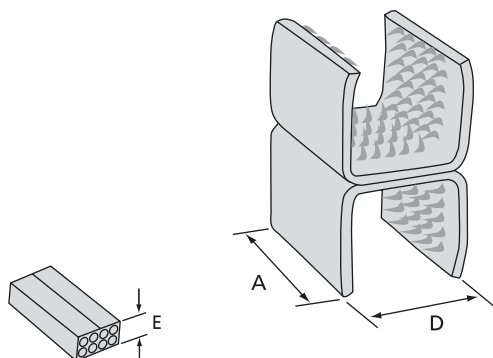

Approvals



E9809

Ordering Information

PRODUCT REF.	DIMENSIONS			COMBINED WIRE SIZE	ROUND	RECTANGULAR WIRE RANGE		TOOLING
	A	D	E*		WIRE RANGE	WIRE THICKNESS	WIRE WIDTH	
	[mm]	[mm]	[mm]		MIN - MAX	MIN - MAX	MIN - MAX	
204210SH	17.5	13.5	11.9	(5.20 - 26.60) x2	2.05 (a) - 6.5 (b)	2.5 - 4.1	2.5 - 6.6	13100A, 13400 TBM15i

* Reference dimension (crimped height): see installing die illustration for gauging
 Use selection chart to determine appropriate die set (see pages 358 and 359)
 See pages 354 to 359 for tooling specifications

(a) Six wires max each barrel
 (b) Conductors larger than 13 mm² require special dies

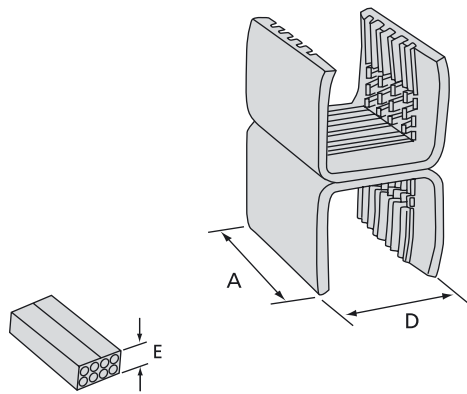

Approvals



E9809

Ordering Information

PRODUCT REF.	DIMENSIONS			COMBINED WIRE SIZE	RECTANGULAR WIRE RANGE		TOOLING
	A	D	E*		WIRE THICKNESS	WIRE WIDTH	
	[mm]	[mm]	[mm]	[mm²]	MIN - MAX	MIN - MAX	
22L009H	17.8	13.8	9.7	(18.25 - 33.5) x 2	1.3 - 4.6	2.0 - 4.5	13100A, 13400 TBM15i

* Reference dimension (crimped height): see installing die illustration for gauging
 Use selection chart to determine appropriate die set (see pages 358 and 359)
 See pages 354 to 359 for tooling specifications

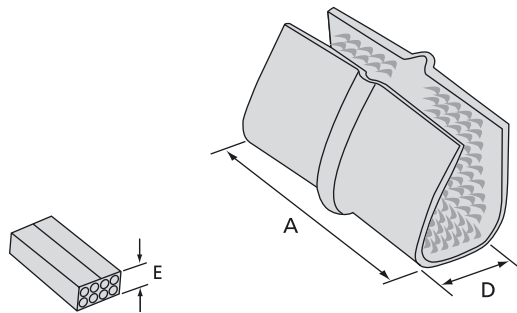

Approvals



E9809

Ordering Information

PRODUCT REF.	DIMENSIONS			COMBINED WIRE SIZE	RECTANGULAR WIRE RANGE		TOOLING
	A	D	E*		WIRE THICKNESS	WIRE WIDTH	
	[mm]	[mm]	[mm]	[mm²]	MIN - MAX	MIN - MAX	
220015	38.1	22.5	(a)	25 - 58	2.5 - 4.4	7.6 - 15.9	13100A TBM15i
220019**	38.1	22.5	(a)	55 - 88	4.4 - 8.3	7.6 - 15.9	
220023	44.5	22.5	(a)	55 - 115	4.4 - 8.3	7.6 - 15.9	

* Reference dimension (crimped height): see installing die illustration for gauging
 ** Not UL recognised
 Use selection chart to determine appropriate die set (see pages 358 and 359)
 See pages 354 to 359 for tooling specifications

(a) Crimping dies may not bottom.
 Connector height will depend on number and sizes of wires in barrel.
 Pump must deliver 9.800 psi min.

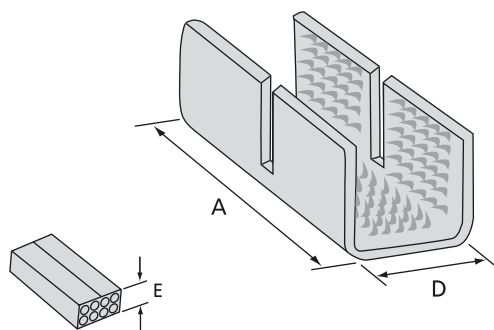

Ordering Information

PRODUCT REF.	DIMENSIONS			COMBINED WIRE SIZE	ROUND	RECTANGULAR WIRE RANGE		TOOLING
	A	D	E*		WIRE RANGE	WIRE THICKNESS	WIRE WIDTH	
	[mm]	[mm]	[mm]		MIN - MAX	MIN - MAX	MIN - MAX	
314118S	16.0	9.7	3.3	1.65 - 6.25	1.45 - 1.83	1.27 - 1.52	1.27 - 4.57	13100A, 13400, TBM15i

* Reference dimension (crimped height): see installing die illustration for gauging
 Use selection chart to determine appropriate die set (see pages 358 and 359)
 See pages 354 to 359 for tooling specifications

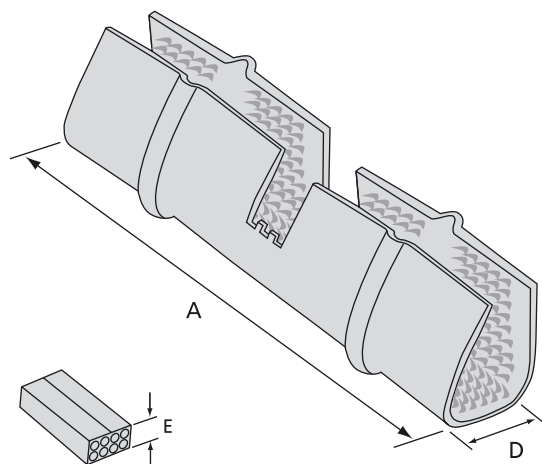

Approvals



E9809

Ordering Information

PRODUCT REF.	DIMENSIONS			COMBINED WIRE SIZE	RECTANGULAR WIRE RANGE		TOOLING
	A	D	E*		WIRE THICKNESS	WIRE WIDTH	
	[mm]	[mm]	[mm]		MIN - MAX	MIN - MAX	
220016	79.5	22.5	(a)	(25.0 - 58.0) x 2	2.5 - 4.4	7.6 - 15.9	13100A TBM15i
220020	79.5	22.5	(a)	(55.0 - 88.6) x 2	2.5 - 4.4	7.6 - 15.9	
220024	92.2	22.5	(a)	(55.0 - 116.0) x 2	2.5 - 4.4	7.6 - 15.9	

* Reference dimension (crimped height): see installing die illustration for gauging
 Use selection chart to determine appropriate die set (see pages 358 and 359)
 See pages 354 to 359 for tooling specifications

Dragon Tooth®

Ring terminals

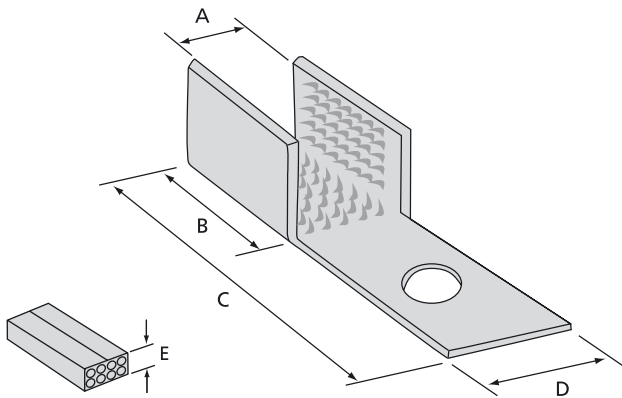

Approvals



Ordering Information

PRODUCT REF.	USA STUD SIZE**	DIMENSIONS					COMBINED WIRE SIZE	ROUND	RECTANGULAR WIRE RANGE		TOOLING****
		A	B	C	D	E*		WIRE RANGE	THICKNESS	WIDTH	
		[mm]	[mm]	[mm]	[mm]	[mm]	MIN - MAX	MIN - MAX	MIN - MAX		
210219	8	9.5	14.3	31.0	10.3	4.3	2.1 - 10.5	1.63 (a) - 2.58	2.0 - 2.3	2.0 - 4.5	
210217	10	9.5	14.3	31.0	10.3	4.3	2.1 - 10.5	1.63 (a) - 2.58	2.0 - 2.3	2.0 - 4.5	
210216	1/4	9.5	14.3	31.0	10.3	4.3	2.1 - 10.5	1.63 (a) - 2.58	2.0 - 2.3	2.0 - 4.5	13100A
204217	10	13.5	15.5	40.1	12.7	6.4	5.2 - 26.6	2.05 (b) - 6.5 (c)	2.5 - 4.1	2.5 - 6.35	13400
204212	1/4	13.5	15.5	40.1	12.7	6.4	5.2 - 26.6	2.05 (b) - 6.5 (c)	2.5 - 4.1	2.5 - 6.35	TBM15i
314125***	10	9.7	14.2	31.0	10.3	6.9	1.7 - 6.2	1.45 - 1.83	1.27 - 1.52	1.27 - 4.57	
314123***	1/4	9.7	14.2	35.7	10.3	6.9	1.7 - 6.2	1.45 - 1.83	1.27 - 1.52	1.27 - 4.57	

* Reference dimension (crimp height): see installing die illustration for gauging

(a) Four wires max

** USA stud size: see page 338 for metric conversion

(b) Six wires max

*** Not UL recognised

(c) Conductors larger than 13 mm² require special dies

**** Use selection chart to determine appropriate die set (see pages 358 and 359)

See pages 354 to 359 for tooling specifications

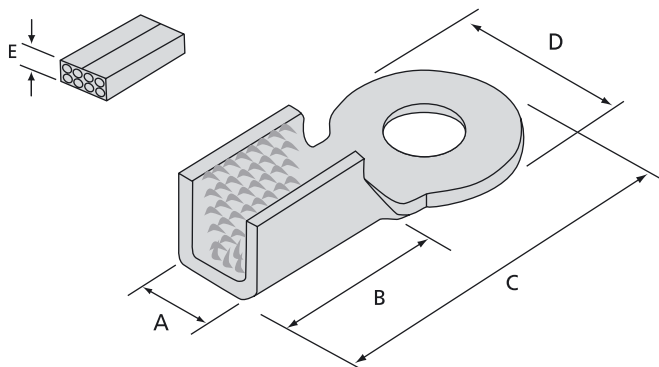

Approvals



E9809

Ordering Information

PRODUCT REF.	USA STUD SIZE**	DIMENSIONS					COMBINED WIRE SIZE	ROUND	RECTANGULAR WIRE RANGE		TOOLING***
		A	B	C	D	E*		WIRE RANGE	THICKNESS	WIDTH	
		[mm]	[mm]	[mm]	[mm]	[mm]	[mm ²]	MIN - MAX [mm]	MIN - MAX [mm]	MIN - MAX [mm]	
210214-1	1/4	9.5	14.3	35.7	17.5	4.3	2.0 - 10.5	1.6 (a) - 2.58	2.0 - 2.3	2.0 - 4.6	
210214-2	5/16	9.5	14.3	35.7	17.5	4.3	2.0 - 10.5	1.6 (a) - 2.58	2.0 - 2.3	2.0 - 4.6	
210214-3	3/8	9.5	14.3	35.7	17.5	4.3	2.0 - 10.5	1.6 (a) - 2.58	2.0 - 2.3	2.0 - 4.6	13100A
204210-1	1/4	13.5	15.5	40.1	20.6	6.3	5.2 - 26.6	2.05 (b) - 6.5 (c)	2.5 - 4.1	2.5 - 6.6	13400
204210-2	5/16	13.5	15.5	40.1	20.6	6.3	5.2 - 26.6	2.05 (b) - 6.5 (c)	2.5 - 4.1	2.5 - 6.6	TBM15i
204210-3	3/8	13.5	15.5	40.1	20.6	6.3	5.2 - 26.6	2.05 (b) - 6.5 (c)	2.5 - 4.1	2.5 - 6.6	
204210-5	1/2	13.5	15.5	40.1	20.6	6.3	5.2 - 26.6	2.05 (b) - 6.5 (c)	2.5 - 4.1	2.5 - 6.6	

* Reference dimension (crimped height): see installing die illustration for gauging

** USA stud size: see page 338 for metric conversion

*** Use selection chart to determine appropriate die set (see pages 358 and 359)

See pages 354 to 359 for tooling specifications

(a) Four wires max

(b) Six wires max

(c) Conductors larger than 13 mm² require special dies

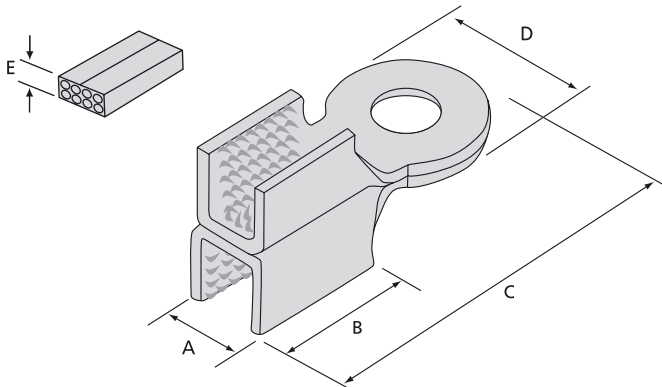

Approvals



E9809

Ordering Information

PRODUCT REF.	USA STUD SIZE**	DIMENSIONS					COMBINED WIRE SIZE	ROUND WIRE RANGE MIN - MAX	RECTANGULAR WIRE RANGE		TOOLING***
		A	B	C	D	E*			THICKNESS MIN - MAX	WIDTH MIN - MAX	
		[mm]	[mm]	[mm]	[mm]	[mm]	[mm ²]	[mm]	[mm]	[mm]	
204210-1H	1/4	13.5	15.5	40.1	20.6	11.9	(5.2 - 26.6) x 2	2.05 (a) - 6.54 (b)	2.5 - 4.1	2.5 - 6.6	13100A,13400
204210-3H	3/8	13.5	15.5	40.1	20.6	11.9	(5.2 - 26.6) x 2	2.05 (a) - 6.54 (b)	2.5 - 4.1	2.5 - 6.6	TBM15i

* Reference dimension (crimped height): see installing die illustration for gauging

(a) Six wires max

** USA stud size: see page 338 for metric conversion

(b) Conductors larger than 13 mm² require special dies

*** Use selection chart to determine appropriate die set (see pages 358 and 359)

See pages 354 to 359 for tooling specifications

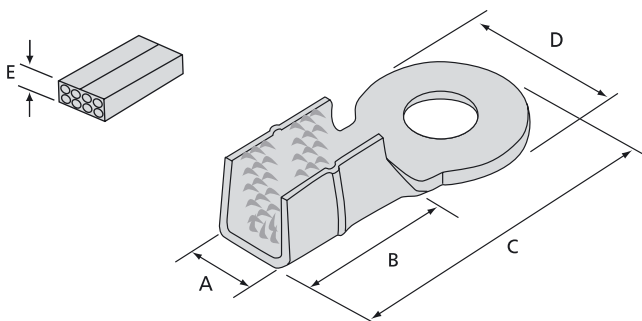

Approvals



E9809

Ordering Information

PRODUCT REF.	USA STUD SIZE**	DIMENSIONS					COMBINED WIRE SIZE	RECTANGULAR WIRE RANGE		TOOLING***
		A	B	C	D	E*		THICKNESS MIN - MAX	WIDTH MIN - MAX	
		[mm]	[mm]	[mm]	[mm]	[mm]	[mm ²]	[mm]	[mm]	
220017	3/8	22.4	38.1	70.1	26.9	(a)	25.3 - 58.2	2.5 - 4.4	7.6 - 15.9	
220018	1/2	22.4	38.1	70.1	26.9	(a)	25.3 - 58.2	2.5 - 4.4	7.6 - 15.9	
220021 (b)	3/8	22.4	38.1	70.1	26.9	(a)	55.7 - 88.7	4.4 - 6.4	7.6 - 15.9	13100A
220022 (b)	1/2	22.4	38.1	70.1	26.9	(a)	55.7 - 88.7	4.4 - 6.4	7.6 - 15.9	TBM15i
220025	3/8	22.4	38.1	70.1	26.9	(a)	55.7 - 116.8	4.4 - 8.3	7.6 - 15.9	
220026	1/2	22.4	38.1	70.1	26.9	(a)	55.7 - 116.8	4.4 - 8.3	7.6 - 15.9	

* Reference dimension (crimped height): see installing die illustration for gauging

(a) Crimping dies may not bottom.

** USA stud size: see page 338 for metric conversion

Connector height will depend on number and size of wires in barrel. Pump must deliver 9.800 psi min.

*** Use selection chart to determine appropriate die set (see pages 358 and 359)

See pages 354 to 359 for tooling specifications

(b) Not UL approved

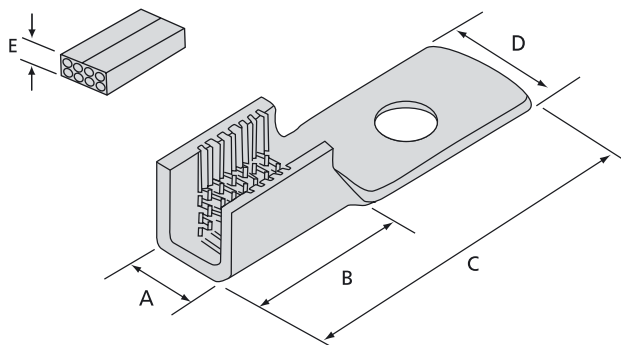

Approvals



E9809

Ordering Information

PRODUCT REF.	USA STUD SIZE**	DIMENSIONS					COMBINED WIRE SIZE	ROUND	RECTANGULAR WIRE RANGE		TOOLING	
		A	B	C	D	E*		WIRE RANGE	THICKNESS	WIDTH	HAND TOOL	POWER TOOL***
		[mm]	[mm]	[mm]	[mm]	[mm]	[mm ²]	MIN - MAX [mm]	MIN - MAX [mm]	MIN - MAX [mm]		
22R061(a)	6	4.1	8.1	19.8	7.6	2.5	0.2 - 2.1	0.51 - 1.45	0.51 - 1.27	0.51 - 2.54		
22R081(a)	8	4.1	8.1	19.8	7.6	2.5	0.2 - 2.1	0.51 - 1.45	0.51 - 1.27	0.51 - 2.54	ERG1801	11903A
22R101(a)	10	4.1	8.1	19.8	7.6	2.5	0.2 - 2.1	0.51 - 1.45	0.51 - 1.27	0.51 - 2.54	11904A	
22R086	8	6.4	11.5	23.1	7.6	3.3	1.3 - 6.2	1.29 - 2.05	1.27 - 2.03	1.27 - 4.06	ERG1806	13500
22R106	10	6.4	11.5	23.1	7.6	3.3	1.3 - 6.2	1.29 - 2.05	1.27 - 2.03	1.27 - 4.06		

* Reference dimension (crimped height): see installing die illustration for gauging

** USA stud size: see page 338 for metric conversion

*** Use selection chart to determine appropriate die set (see pages 358 and 359)

See pages 354 to 359 for tooling specifications

(a) 0.51 - 0.64 mm diameter and equivalent rectangular wire size, copper only

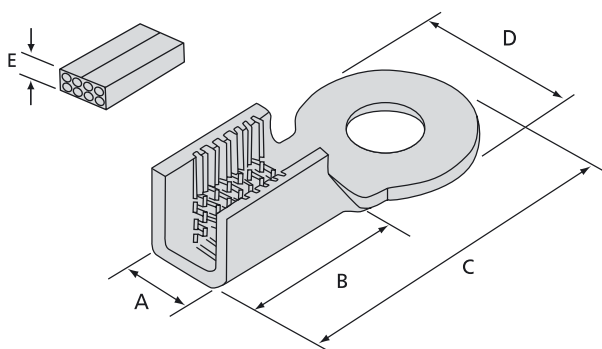

Approvals



E9809

Ordering Information

PRODUCT REF.	USA STUD SIZE**	DIMENSIONS					COMBINED WIRE SIZE	ROUND	RECTANGULAR WIRE RANGE		TOOLING	
		A	B	C	D	E*		WIRE RANGE	THICKNESS	WIDTH	HAND TOOL	POWER TOOL***
		[mm]	[mm]	[mm]	[mm]	[mm]	[mm ²]	MIN - MAX [mm]	MIN - MAX [mm]	MIN - MAX [mm]		
22R146	1/4	6.4	11.5	24.2	10.7	3.3	1.3 - 6.2	1.29 - 2.05	1.27 - 2.03	1.27 - 4.06	ERG1806	11903A 11904A 13500

* Reference dimension (crimped height): see installing die illustration for gauging

** USA stud size: see page 338 for metric conversion

*** Use selection chart to determine appropriate die set (see pages 358 and 359)

See pages 354 to 359 for tooling specifications

Dragon Tooth®

Fork terminals

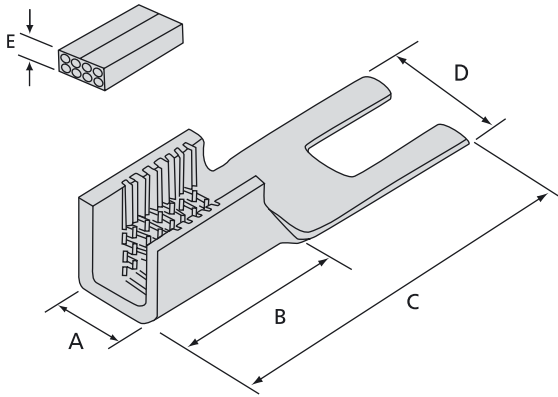

5.3

Approvals



E9809

Ordering Information

PRODUCT REF.	USA STUD SIZE**	DIMENSIONS					COMBINED WIRE SIZE	ROUND WIRE RANGE MIN - MAX	RECTANGULAR WIRE RANGE		TOOLING	
		A	B	C	D	E*			THICKNESS MIN - MAX	WIDTH MIN - MAX	HAND TOOL	POWER TOOL***
		[mm]	[mm]	[mm]	[mm]	[mm]	[mm ²]	[mm]	[mm]	[mm]		
22F061(a)	6	4.1	8.1	19.8	7.6	2.5	0.2 - 2.1	0.51 - 1.45	0.51 - 1.27	0.51 - 2.54		
22F081(a)	8	4.1	8.1	19.8	7.6	2.5	0.2 - 2.1	0.51 - 1.45	0.51 - 1.27	0.51 - 2.54	ERG1801	11903A
22F101(a)	10	4.1	8.1	19.8	7.6	2.5	0.2 - 2.1	0.51 - 1.45	0.51 - 1.27	0.51 - 2.54		11904A
22F066	6	6.4	11.4	23.1	7.6	3.3	1.3 - 6.2	1.29 - 2.05	1.27 - 2.03	1.27 - 4.06		
22F086	8	6.4	11.4	23.1	7.6	3.3	1.3 - 6.2	1.29 - 2.05	1.27 - 2.03	1.27 - 4.06	ERG1806	13500
22F106	10	6.4	11.4	23.1	7.6	3.3	1.3 - 6.2	1.29 - 2.05	1.27 - 2.03	1.27 - 4.06		

* Reference dimension (crimped height): see installing die illustration for gauging

** USA stud size: see page 338 for metric conversion

*** Use selection chart to determine appropriate die set (see pages 358 and 359)

See pages 354 to 359 for tooling specifications

(a) 0.51 - 0.64 mm diameter and equivalent rectangular wire size, copper only

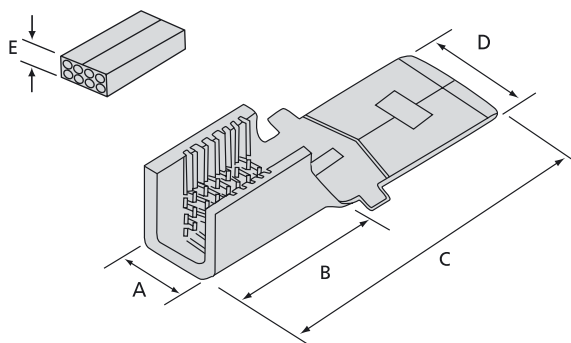

Approvals



E9809

Ordering Information

PRODUCT REF.	MALE TAB SIZE	DIMENSIONS					COMBINED WIRE SIZE	ROUND WIRE RANGE MIN - MAX	RECTANGULAR WIRE RANGE		TOOLING	
		A	B	C	D	E*			THICKNESS MIN - MAX	WIDTH MIN - MAX	HAND TOOL	POWER TOOL**
	[mm x mm]	[mm]	[mm]	[mm]	[mm]	[mm]	[mm ²]	[mm]	[mm]	[mm]		
22LM01***	6.35 x 0.8	4.1	8.1	19.3	6.4	2.5	0.2 - 2.1	0.50 - 1.45	0.51 - 1.27	0.5 - 2.5	ERG1801	11903A, 11904A
22LM06	6.35 x 0.8	6.4	11.5	23.0	6.4	3.3	1.3 - 6.2	1.29 - 2.05	1.27 - 2.03	1.3 - 4.1	ERG1806	13500

* Reference dimension (crimped height): see installing die illustration for gauging

** Use selection chart to determine appropriate die set (see pages 358 and 359)

*** 0.51 - 0.64 mm diameter and equivalent wire size, copper only

See pages 354 to 359 for tooling specifications

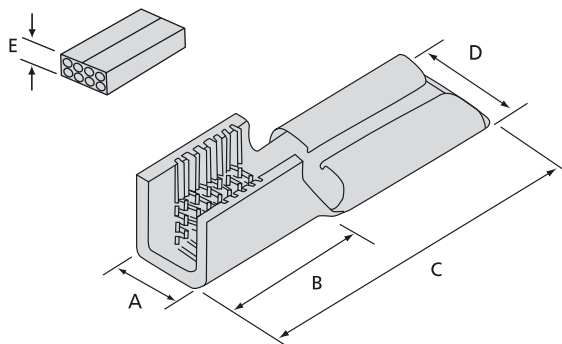

Approvals



E9809

Ordering Information

PRODUCT REF.	MALE TAB SIZE	DIMENSIONS					COMBINED WIRE SIZE	ROUND WIRE RANGE MIN - MAX	RECTANGULAR WIRE RANGE		TOOLING	
		A	B	C	D	E*			THICKNESS MIN - MAX	WIDTH MIN - MAX	HAND TOOL	POWER TOOL**
	[mm x mm]	[mm]	[mm]	[mm]	[mm]	[mm]	[mm ²]	[mm]	[mm]	[mm]		
22LF01***	6.3 x 0.8	4.1	8.1	20.1	6.4	2.5	0.2 - 2.1	0.50 - 1.45	0.51 - 1.27	0.5 - 2.5	ERG1801	11903A, 11904A
22LF06	6.3 x 0.8	6.4	11.5	23.0	6.4	3.3	1.3 - 6.2	1.29 - 2.05	1.27 - 2.03	1.3 - 4.1	ERG1806	13500

* Reference dimension (crimped height): see installing die illustration for gauging

** Use selection chart to determine appropriate die set (see pages 358 and 359)

*** 0.51 - 0.64 mm diameter and equivalent wire size, copper only

See pages 354 to 359 for tooling specifications

Dragon Tooth®

Taps

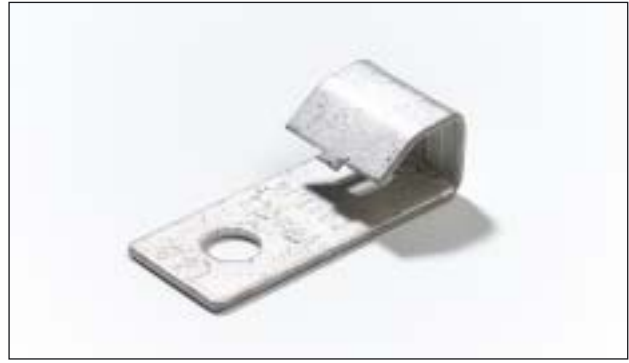
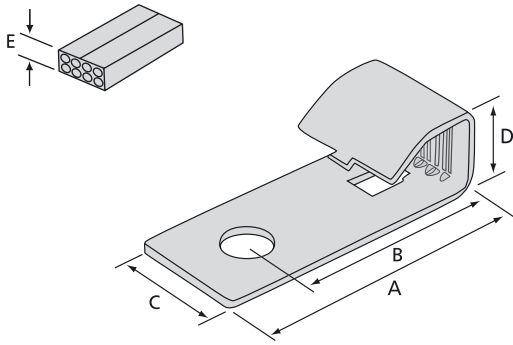

Approvals



E9809

Ordering Information

PRODUCT REF.	USA STUD SIZE**	DIMENSIONS					COMBINED WIRE SIZE	ROUND WIRE RANGE MIN - MAX	RECTANGULAR WIRE RANGE		TOOLING
		A	B	C	D	E*			THICKNESS MIN - MAX	WIDTH MIN - MAX	
		[mm]	[mm]	[mm]	[mm]	[mm]	[mm ²]	[mm]	[mm]	[mm]	
204T14	1/4	41.2	31.0	17.8	12.7	5.6	5.2 - 26.6	2.58 - 4.1	2.3 - 2.9	2.3 - 8.1	13100A
204T38	3/8	41.2	31.0	17.8	12.7	5.6	5.2 - 26.6	2.58 - 4.1	2.3 - 2.9	2.3 - 8.1	TBM15i

* Reference dimension (crimped height): see installing die illustration for gauging

** USA stud size: see page 338 for metric conversion

Use selection chart to determine appropriate die set (see pages 358 and 359)

See pages 354 to 359 for tooling specifications

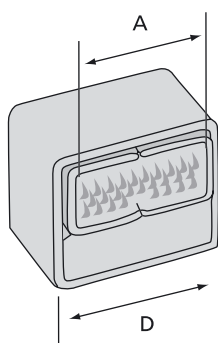

Approvals



E9809

Ordering Information

PRODUCT REF.	DIMENSIONS			COMBINED WIRE SIZE [mm ²]	ROUND WIRE RANGE MIN - MAX [mm]	RECTANGULAR WIRE RANGE		TOOLING
	A [mm]	D [mm]	E* [mm]			WIRE THICKNESS MIN - MAX [mm]	WIRE WIDTH MIN - MAX [mm]	
210214MT	16.0	19.1	(a)	10.1 - 53.2	1.8 - 4.62	2.0 - 3.8 (upper half) 6.4 max. (lower half)	2.0 - 12.4 (upper half) 19.1 max. (lower half)	13100A 13400, TBM15i
204210MT	23.8	26.2	(a)	45.6 - 108.9	2.6 - 5.84	2.5 - 6.8 (upper half) 6.4 max. (lower half)	2.5 - 2.3 (upper half) 26.1 max. (lower half)	13400

* Reference dimension (crimped height): see installing die illustration for gauging

(a) Crimping dies may not bottom. Connector height will depend on number and size of wires in barrel. Pump must deliver 9.800 psi min.

Note: combined wire size is for the whole connector (including upper half and lower half)

Use selection chart to determine appropriate die set (see pages 358 and 359)

See pages 354 to 359 for tooling specifications

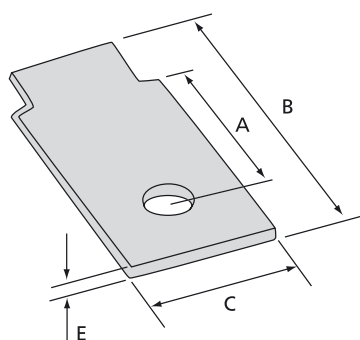

Approvals



E9809

Ordering Information

PRODUCT REF.	USA STUD SIZE**	DIMENSIONS			E* [mm]	DESCRIPTION
		A [mm]	B [mm]	C [mm]		
210MT14	1/4	25.4	36.5	20.8	2.3	Screw-on clip for connectors 210214MT
210MT38	3/8	25.4	36.5	20.8	2.3	Screw-on clip for connectors 210214MT
204MT14	1/4	25.4	36.5	23.1	3.0	Screw-on clip for connectors 204210MT
204MT38	3/8	25.4	36.5	23.1	3.0	Screw-on clip for connectors 204210MT

* Reference dimensions: see installing die illustration for gauging

** USA stud size: see page 338 for metric conversion

Dragon Tooth®

Washers

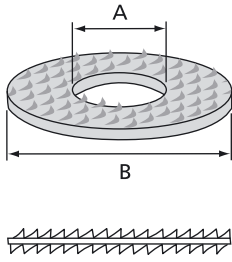

Teeth on the transition washers penetrate aluminium and copper oxides, enabling copper to aluminium connections to be made in a bolted joint without the use of inhibiting compounds. Transition washers also accommodate the difference in thermal expansion between copper and aluminium, and enhance the efficiency of bolted grounding connections.

Ordering Information

PRODUCT REF.	USA STUD SIZE*	METRIC EQUIVALENT STUD SIZE	A [mm]	B [mm]	RECOMMENDED INSTALLING TORQUE [Nm]
FPW14	1/4	M6	6.9	17.3	5.5 - 9
FPW516	5/16	M8	8.6	25.4	14 - 18
FPW38	3/8	M10	10.9	25.4	18 - 27
FPW12	1/2	M14	14.2	31.8	44 - 61
FPW58	5/8	M16	17.3	35.6	61 - 82.5

* USA stud size: see page 338 for metric conversion

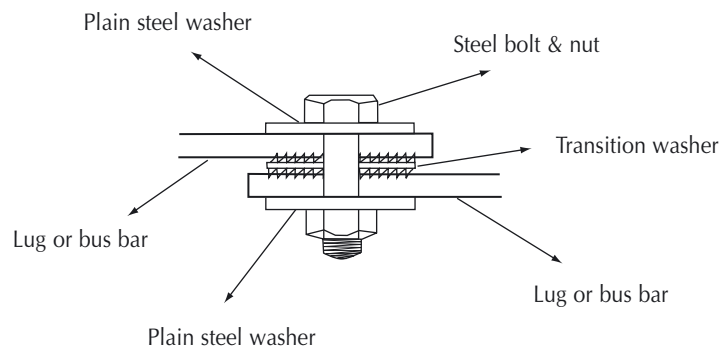

These manually operated tools are suitable for prototyping and limited production usage. They are equipped with a Shure-Stake™ mechanism which requires full closure of the dies before release. Appropriate to crimp butt splices, parallel splices, taps and terminations. Dies are self-contained.

Ergonomic hand tools

- Fixed die tool
- Incorporates the ergonomically designed Comfort Crimp™ tool handles which distribute the force more evenly across the hand
- Shure-Stake™ mechanism ensures a complete crimp cycle before the tool releases
- Rubberised thermoplastic handles combine maximum friction with a soft, comfortable feel that reduces muscle tension
- Two-piece movable die nest provides easy connector removal

Standard hand tool

Product Ref. WT811

- Hand operated crimping tool with single die for installing Thomas & Betts insulation piercing connectors on magnet wire
- Incorporates a Shure-Stake™ mechanism which will not allow the dies to open until preset crimping is reached.
- Single die nest for 214420 connector only
- Weight: 0.45 kg
- Material: high strength steel
- Maintenance: Occasional light oiling



Ordering Information

PRODUCT REF.	TOOL GAUGING [mm]	CONNECTOR
ERG1801	1.75 max.	22,F,L,R-1 Series
ERG1802	1.93 max.	22L002
ERG1804	0.86 max.	22L004
ERG1806	2.41 max.	22,F,L,R-6 Series
ERG811	–	214420



Dragon Tooth®

Air-operated tools

Air hydraulic tool

This pneumatic operated crimping tool will install Dragon Tooth® terminals. It is available in hand or foot actuated models, with open "C" yoke design.

The 3 interchangeable dies can crimp the 22xxx1, 22xxx2 and 22xxx6 series terminals and need to be ordered separately (see below for the Product Ref. of the dies)

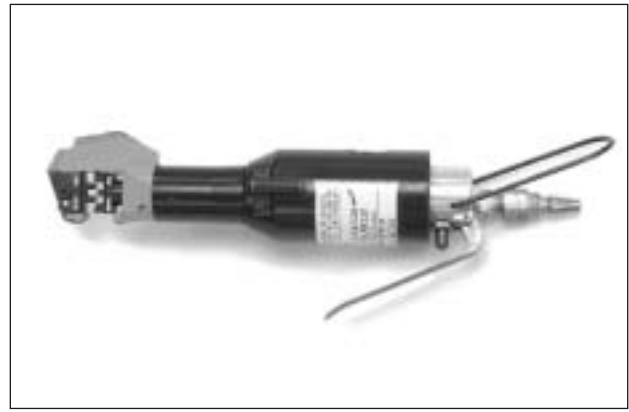

Ordering Information Air hydraulic tool

PRODUCT REF.	DESCRIPTION
11903A	Open "C" yoke, hand actuated
11904A	Open "C" yoke, foot actuated
11913	2.43 m long airhose with 1/4 NPT male & female fittings
11930	Foot valve for 11904A

Product Ref. 11904A also requires two Product Ref. 11913 air hoses and one Product Ref. 11930 foot valve.

Product Ref. 11903A also requires one Product Ref. 11913 air hose.

Technical Information 11903A and 11904A

Material	Steel with backed enamel paint finish
Overall length	276 mm
Diameter	57 mm
Operating Pressure	90 - 100 PSI (6.3-7.0 bar)
Weight	1.4 kg

Air operated – bench mounted tool

Product Ref.: 13500

Heavy duty air operated tool installs a wide range of Dragon Tooth® connectors.

- High speed installation
- 3 interchangeable dies to be ordered separately (see below for the Product Ref. of the dies)
- Bench mounted for stability and operator control
- Compact size, all metallic construction
- Includes hoses, foot pedal and air treatment system
- Equipped with Shure-Stake™ mechanism ensuring full crimp cycle before release



Technical Information

Height	305 mm
Base	203 mm x 203 mm
Weight	7.7 kg
Operating Pressure	(85 - 90 PSI) 6.0-6.3 bar

Ordering Information - Dies

PRODUCT REF.	COLOUR CODE	CONNECTOR	DIE GAUGE	
			MAX.	MIN.
13201	pink	22XXX1 SERIES	1.68	1.57
13202	brown	22XXX2 SERIES	1.83	1.73
13206	yellow	22XXX6 SERIES	2.29	2.18

Compatible with 11903A, 11904A and 13500 air operated tools.

Note: 11903A, 11904A and 13500 tools also accept dies for Thomas & Betts Sta-Kon® 0.5 - 0.6 mm² insulated and non-insulated terminals.

Installing Dies for 11903A, 11904A & 13500 Tools

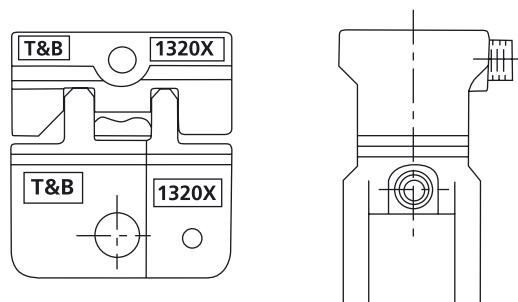

Auto-feed tools for connectors on strip

Pneumatic bench mounted foot operated tool for crimping copper or aluminium magnet wire and copper lead wire, not solder dipped or bonded.

- Operates on min. 6.0 bar air supply
- Foot pedal contains T&B Shure-Stake™ control mechanism which ensures a full compression each time
- Insulation piercing connectors are fed on a continuous reel mounted strip
- Dies are self-contained. Includes foot valve, hoses and air treatment system



Ordering Information

PRODUCT REF.	CONNECTOR PRODUCT REF.	CONNECTOR QTY PER REEL	TOOL WEIGHT [mm]	TOOL WIDTH [mm]	TOOL DEPTH [mm]	TOOL HEIGHT [mm]
13676A	220004	9000	8.6	127	356	279
13678	220001	3000	12.7	152	457	356
13679	220002-TB	3000	12.7	152	457	356
13696	220006	2500	14.5	152	457	406

14 Ton hydraulic head

Product Ref.: 13100A

- Output: 14 tons (nominal)
 - Hydraulic operating pressure: 10,000 psi max.
 - Length (with coupling): 292 mm
 - Width: 108 mm
 - Weight (without dies): 4.5 kg
 - Dies delivered separately
- See selection chart on pages 358 and 359 for complete listing of dies and connectors used with 13100A.



12 Ton hydraulic head

Product Ref.: 13400

- Output: 12 tons (nominal)
 - Hydraulic operating pressure: 10,000 psi max.
 - Length (with coupling): 368 mm
 - Width: 84 mm
 - Weight (without dies): 6.8 kg
 - Dies delivered separately
- See selection chart on pages 358 and 359 for complete listing of dies and connectors used with 13400.



15 Ton hydraulic head

Product Ref.: TBM15I

- New longer, slimmer profile allows easier access into tight spaces
 - Wider jaw opening eases crimping of larger connectors
 - Available with an insulated head
 - Supplied in a carrying case in steel
 - Output force: 15 tons (nominal)
 - Operating pressure: 10,000 psi (nominal)
 - Tool weight: 7 kg (without dies)
 - Dies delivered separately
- See selection chart on pages 358 and 359 for complete listing of dies and connectors used with TBM15i.

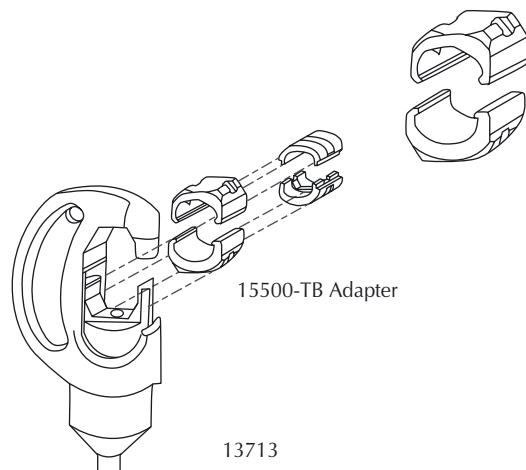

Selection chart - connectors and tooling

	Hand tools (fixed die)	Pneumatic tools 11903A, 11904-A 13500	Auto-feed tool for magnet wire on strip	14 ton hydraulic head 13100A	12 ton hydraulic head 13400	15 ton hydraulic head TBM15i
TERMINALS	TOOL	DIE	TOOL	DIE	DIE	DIE + ADAPTOR
204210MT	-	-	-	-	13682	-
204210S	-	-	-	13671B	13671A	13671B with 15500TB
204210SH	-	-	-	13673B	13673	13673B with 15500TB
214210-1	-	-	-	13671B	13671A	13671B with 15500TB
204210-1H	-	-	-	13673B	13673	13673B with 15500TB
204210-2	-	-	-	13671B	13671A	13671B with 15500TB
204210-3	-	-	-	13671B	13671A	13671B with 15500TB
204210-3H	-	-	-	13673B	13673	13673B with 15500TB
204201-5	-	-	-	13671B	13671A	13671B with 15500TB
204211	-	-	-	13671B	13671A	13671B with 15500TB
204212	-	-	-	13671B	13671	13671B with 15500TB
204217	-	-	-	13671B	13671A	13671B with 15500TB
204MT14	-	-	-	-	-	-
204MT38	-	-	-	-	-	-
204T14	-	-	-	13689B	-	13689B with 15500TB
204T38	-	-	-	13689B	-	13689B with 15500TB
210214MT	-	-	-	13681B	13681	13681B with 15500TB
210214S	-	-	-	13670B	13670A	13670B with 15500TB
210214-2	-	-	-	13670B	13670A	13670B with 15500TB
210214-3	-	-	-	13670B	13670A	13670B with 15500TB
210216	-	-	-	13670B	13670A	13670B with 15500TB
210217	-	-	-	13670B	13670A	13670B with 15500TB
210219	-	-	-	13670B	13670A	13670B with 15500TB
210MT14	-	-	-	-	-	-
210MT38	-	-	-	-	-	-
214420	WT811 / ERG811	1195	-	-	-	-
220001	-	-	13678	-	-	-
220002-TB	-	-	13679	-	-	-
220004	-	-	13676A	-	-	-
220006	-	-	13696	-	-	-
220015	-	-	-	13713B	-	13713B
220016	-	-	-	13713B	-	13713B
220017	-	-	-	13713B	-	13713B
220018	-	-	-	13713B	-	13713B
220019	-	-	-	13713B	-	13713B
220020	-	-	-	13713B	-	13713B
220021	-	-	-	13713B	-	13713B
220022	-	-	-	13713B	-	13713B
220023	-	-	-	13713B	-	13713B
220024	-	-	-	13713B	-	13713B
220025	-	-	-	13713B	-	13713B
220026	-	-	-	13713B	-	13713B

(continued on page 359)

Selection chart - connectors and tooling

	Hand tools (fixed die)	Pneumatic tools 11903A, 11904-A 13500	Auto-feed tool for magnet wire on strip	14 ton hydraulic head 13100A	12 ton hydraulic head 13400	15 ton hydraulic head TBM15i
TERMINALS	TOOL	DIE	TOOL	DIE	DIE	DIE + ADAPTOR
22F061	ERG1801	13201	-	-	-	-
22F066	ERG1806	13206	-	-	-	-
22F081	ERG1801	13201	-	-	-	-
22F086	ERG1806	13206	-	-	-	-
22F101	ERG1801	13201	-	-	-	-
22F106	ERG1806	13206	-	-	-	-
22L001	ERG1801	13201	-	-	-	-
22L002	ERG1802	13202	-	-	-	-
22L004	ERG1804	-	-	-	-	-
22L006	ERG1806	13206	-	-	-	-
22L008	-	-	-	13683B	13683	13683B with 15500TB
22L009	-	-	-	13684B	13684	13684B with 15500TB
22L009H	-	-	-	13686B	13686	13686B with 15500TB
22LF01	ERG1801	13201	-	-	-	-
22LF06	ERG1806	13206	-	-	-	-
22LM01	ERG1801	13201	-	-	-	-
22LM06	ERG1806	13206	-	-	-	-
22R061	ERG1801	13201	-	-	-	-
22R106	ERG1806	13206	-	-	-	-
22R146	ERG1806	13206	-	-	-	-
314118S	-	-	-	13685B	13685	13685B with 15500TB
314123	-	-	-	13685B	13685	13685B with 15500TB
314125	-	-	-	13685B	13685	13685B with 15500TB

Note: Dies that fit 13100A also work in TBM15i with use of adapter 15500TB.